



**TEST REPORT**

Rendered to:

**COLLINS LIMITED**

For:

**PRODUCT: 6 ft x 6 ft and 6 ft x 8 ft Vinyl Privacy Fence Systems**

<b>Report No.:</b>	<b>G7563.01-119-16</b>
<b>Test Date:</b>	<b>03/29/17</b>
<b>Report Date:</b>	<b>07/07/17</b>
<b>Test Record Retention Date:</b>	<b>03/29/21</b>
<b>Revision 1:</b>	<b>07/11/17</b>
<b>Revision 2:</b>	<b>07/12/17</b>



**TEST REPORT**

G7563.01-119-16

July 7, 2017

---

**TABLE OF CONTENTS**

1.0 General Information ..... 1

2.0 Dynamic Wind Load Testing ..... 1

3.0 Closing Statement ..... 5

Revision Log ..... 6

Appendix A - Drawings

Appendix B - Photographs



## MIAMI-DADE COUNTY TEST REPORT

Rendered to:

COLLINS LIMITED  
PO Box 150  
Dennisville, New Jersey 08214

Report No.: G7563.01-119-16

Test Date: 03/29/17

Report Date: 07/07/17

Test Record Retention Date: 03/29/21

Revision 1: 07/11/17

Revision 2: 07/12/17

### **1.0 General Information**

#### **1.1 Product**

- 1) 6 ft x 6 ft privacy fence using 5-1/2 in PVC brackets for mounting to PVC post
- 2) 6 ft x 8 ft privacy fence using 7 in PVC brackets for mounting to PVC post

#### **1.2 Project Description**

Architectural Testing, Inc., an Intertek company ("Intertek-ATI"), was contracted by Dennisville Fence to perform dynamic wind load tests on their 6 ft x 6 ft and 6 ft x 8 ft vinyl privacy fence systems. Testing was conducted at the Intertek-ATI laboratory in York, Pennsylvania. This report includes comprehensive written and photographic documentation of testing performed.

### **2.0 Dynamic Wind Load Testing**

#### **2.1 Test Specimen**

One specimen of each vinyl privacy fence system were tested. The 6 ft high by 6 ft wide assembly consisted of a 1-panel/2 post fully assembled fence section. The 6 ft high by 8 ft wide assembly consisted of a 2-panel/3-post fully assembled fence section. Dennisville Fence provided all test materials to Intertek-ATI in York, Pennsylvania. Test materials were inspected prior to testing by an Intertek-ATI technician to verify the condition of the materials was suitable for testing. No potentially compromising defects were observed. See drawings in Appendix A for detailed descriptions of assembly and components.

## 2.2 Equipment

One propeller fan wind generator was utilized for testing of the one-panel system and two propeller fan wind generators were utilized for testing of the two-panel system. The propeller of each fan was 84 in diameter and was comprised of four Kevlar composite airfoil units belt-driven by a high-output V8 engine. Wind speeds for the wind generators were calibrated according to AAMA 501.1-05. Deflections were measured with linear displacement transducers accurate to 0.01 inch.

## 2.3 Test Setup

A steel test fixture was designed and fabricated to simulate a rigid post embedment. The bottom of the bottom rail was fixed at two inches above the top of the test fixture. The propeller fan wind generator(s) was positioned 4 ft from the face of the specimen (reference photographs in Appendix B). Linear transducers were fixed on the top rail, middle of the in-fill area, and bottom rail for deflection measurements.

## 2.4 Test Procedure

Wind load testing began at 50 mph and increased until failure or a maximum wind speed of 115 mph. Wind loads were performed with a relaxation period following 50 mph, 75 mph, 85 mph, 95 mph, 105 mph and 115 mph to record permanent set measurements. The duration of the applied wind load at each wind speed was determined by using the following equation:

$$t = 3600 / V_{fm} \text{ (Equation 1)}$$

where:

$t$  = duration (s), required for a one mile long sample of air to pass

$V_{fm}$  = "fastest mile" wind speed (mph)

Wind speeds used in testing correlate with "fastest mile" wind speeds ( $V_{fm}$ ) for reference to codes and design standards. Maximum deflections were recorded at each load level.

## 2.5 Dynamic Wind Load Test Results

See drawings in Appendix A for assembly details and photographs in Appendix B for specimen orientation respective to wind direction.

### Test Series No. 1

**Description:** 6 ft high by 8 ft wide (nominal) 2-panel/3-post PVC privacy fence using PVC collar brackets for mounting to PVC post

**Rails:** Two 1-3/4 in wide by 7 in high by 90-5/16 in long (0.050 in wall) PVC slotted rails per panel

**Rail Reinforcement:** None

**Panels:** Fifteen 7/8 in deep by 6-5/16 in wide (including tongue) by 63-1/2 in long smooth PVC *Glidelock* tongue and groove panels per panel.

**Post:** Three 5 in by 5 in by 99-1/2 in long (0.160 in wall) PVC posts

**Rail Attachment:** Four 7-1/2 in high by 3-1/2 in wide PVC collar brackets per panel, one at each end of top and bottom rail. Each bracket was secured to the post using four #10-10 x 1-1/2" (0.117 in minor diameter) pan head, phillips drive, self-drilling, zinc coated carbon steel screws. Each bracket was secured to the rail using one #10-12 x 1" (0.126 in minor diameter) pan head, phillips drive, self-drilling, zinc coated carbon steel screw on windward side of fence.

**Test Date:** 03/29/17

Wind Speed	Duration	Maximum Deflection (inches)					
		Top		Mid		Bottom	
		Left	Right	Left	Right	Left	Right
50 mph	72 sec	2.03	2.40	1.35	2.30	0.87	1.16
0 mph	Permanent Set	0.67	0.41	0.70	0.41	0.37	0.21
60 mph	60 sec	4.20	3.97	3.15	3.32	1.36	1.70
70 mph	51 sec	5.40	6.10	4.51	5.80	1.85	2.60
75 mph	48 sec	5.90	6.60	4.59	6.10	1.70	3.11
0 mph	Permanent Set	0.35	0.35	0.65	0.27	0.38	0.15
85 mph	42 sec	8.00	9.73	6.49	8.5	2.40	4.70
0 mph	Permanent Set <sup>1</sup>	--	--	--	--	--	--

<sup>1</sup> Deflection readings were not recorded due to equipment malfunction.

**Observation:** Bottom rail broke away from brackets 28 sec into 95 mph.

Maximum Sustained Wind,  $V_{fm} = 85$  mph (equivalent 3-second gust,  $V_{3s} = 100$  mph)

**2.5 Dynamic Wind Load Test Results: (Continued)**

**Test Series No. 2**

**Description:** 6 ft high by 6 ft wide (nominal) 1-panel/2-post PVC privacy fence using PVC collar brackets for mounting to PVC post

**Rails:** Two 1-3/4 in wide by 5-1/2 in high by 66-1/2 in long (0.085 in wall) PVC slotted rails

**Rail Reinforcement:** None

**Panels:** Eleven 7/8 in deep by 6-5/16 in wide (including tongue) by 63-1/2 in long smooth PVC *Glidelock* tongue and groove panels.

**Post:** Two 5 in by 5 in by 99-1/2 in long (0.160 in wall) PVC posts

**Rail Attachment:** Four 6 in high by 3-1/2 in wide PVC collar brackets, one at each end of top and bottom rail. Each bracket was secured to the post using four #10-10 x 1-1/2" (0.117 in minor diameter) pan head, phillips drive, self-drilling, zinc coated carbon steel screws. Each bracket was secured to the rail using one #10-12 x 1" (0.126 in minor diameter) pan head, phillips drive, self-drilling, zinc coated carbon steel screw on windward side of fence.

**Test Date: 03/29/17**

Wind Speed	Duration	Maximum Deflection (inches)		
		Top	Mid	Bottom
50 mph	72 sec	1.93	1.92	0.64
0 mph	Permanent Set	0.11	0.13	0.06
60 mph	60 sec	2.51	2.54	0.81
70 mph	51 sec	3.36	3.86	1.05
75 mph	48 sec	4.00	3.86	1.23
0 mph	Permanent Set	0.23	0.15	0.07
85 mph	42 sec	4.86	4.77	1.49
0 mph	Permanent Set	0.33	0.25	0.18
95 mph	38 sec	5.73	5.34	1.70
0 mph	Permanent Set	0.44	0.33	0.11
105 mph	34 sec	6.35	5.93	1.97
0 mph	Permanent Set	0.57	0.42	0.14
115 mph	31 sec	7.90	7.44	2.45
0 mph	Permanent Set	0.68	0.49	0.20

**Observation:** Infill panels blew out attempting to reach 125 mph

Maximum Sustained Wind,  $V_{fm}$  = 115 mph (equivalent 3-second gust,  $V_{3s}$  = 131 mph)



### 3.0 Closing Statement

Intertek-ATI will service this report for the entire test record retention period. Test records that are retained such as detailed drawings, datasheets, representative samples of test specimens, or other pertinent project documentation will be retained by Intertek-ATI for the entire test record retention period.

Results obtained are tested values and were secured using the designated test methods. This report does not constitute certification of this product nor an opinion or endorsement by this laboratory. It is the exclusive property of the client so named herein and relates only to the specimens tested. This report may not be reproduced, except in full, without the written approval of Intertek-ATI.

For INTERTEK-ATI:

---

Robert G. Spayd  
Technician II

---

V. Thomas Mickley, Jr., P.E.  
Senior Staff Engineer

RGS:vtm/aaa

This report is complete only when all attachments listed are included.

Attachments (pages):

Appendix A - Drawings (8)

Appendix B - Photographs (1)



### Revision Log

<u>Rev. #</u>	<u>Date</u>	<u>Page(s)</u>	<u>Revision(s)</u>
0	07/07/17	N/A	Original report issue
1	07/11/17	Cover, 1	Corrected the size of the fence panels tested
2	07/12/17	Cover, 1	Changed company name and address





G7563.01-119-16-R2

## **APPENDIX A**

### **Drawings**



THE INFORMATION CONTAINED IN THIS DRAWING IS NOT BEING USED IN THE UNITED STATES AND OTHER COUNTRIES, ANY REPRODUCTION IN PART OR AS A WHOLE WITHOUT WRITTEN PERMISSION IS PROHIBITED.

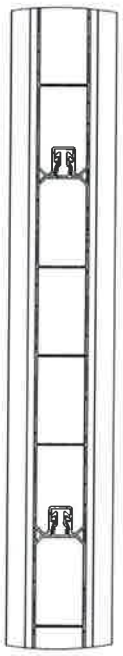
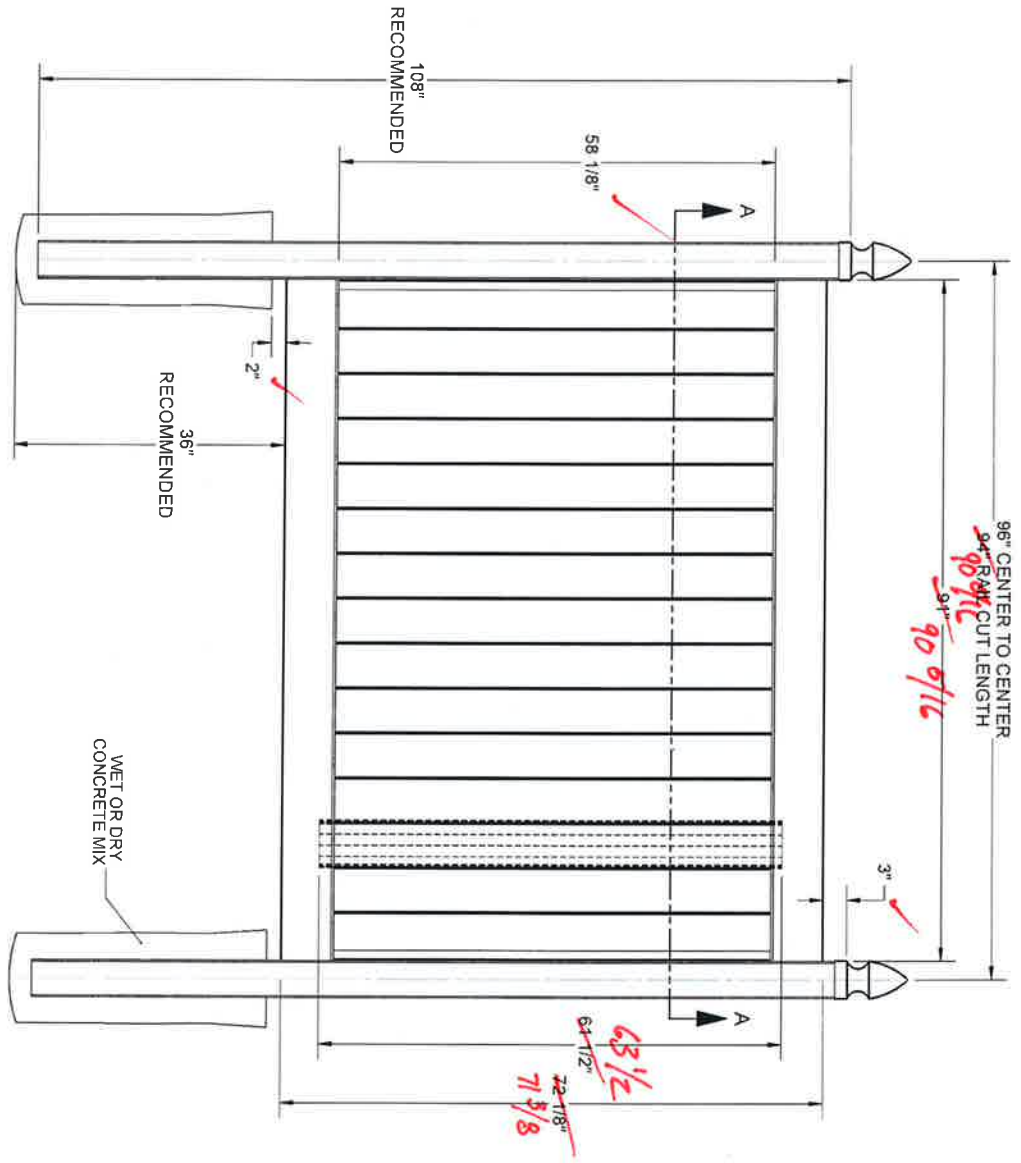

DETAIL B  
SCALE 1 : 2

**Architectural Testing**

Test sample complies with these details.

Deviations are noted.

Report # G7563.01

Date 5/5/17 Tech RGS

<b>Barrette</b>		<b>BARRETTE</b>	
Outdoor Living		Outdoor Living	
749 N. MAIN ST., SUITE 1000, WASH. DC 20771		749 N. MAIN ST., SUITE 1000, WASH. DC 20771	
DESIGNED BY	D. WRIGHT	DATE	8/29/2013
6X8 7" PRIVACY PANEL, WHITE W/CL 72" .035			
SHEET NO.	003	TOTAL SHEETS	003
WEIGHT	181.44	73014530	

THE INFORMATION CONTAINED IN THIS DRAWING IS NOT TO BE REPRODUCED OR TRANSMITTED IN ANY FORM OR BY ANY MEANS, ELECTRONIC OR MECHANICAL, INCLUDING PHOTOCOPYING, RECORDING, OR BY ANY INFORMATION STORAGE AND RETRIEVAL SYSTEM, WITHOUT THE WRITTEN PERMISSION OF THE COPYRIGHT HOLDER. ANY REPRODUCTION IN ANY FORM OR BY ANY MEANS WITHOUT THE WRITTEN PERMISSION IS PROHIBITED.

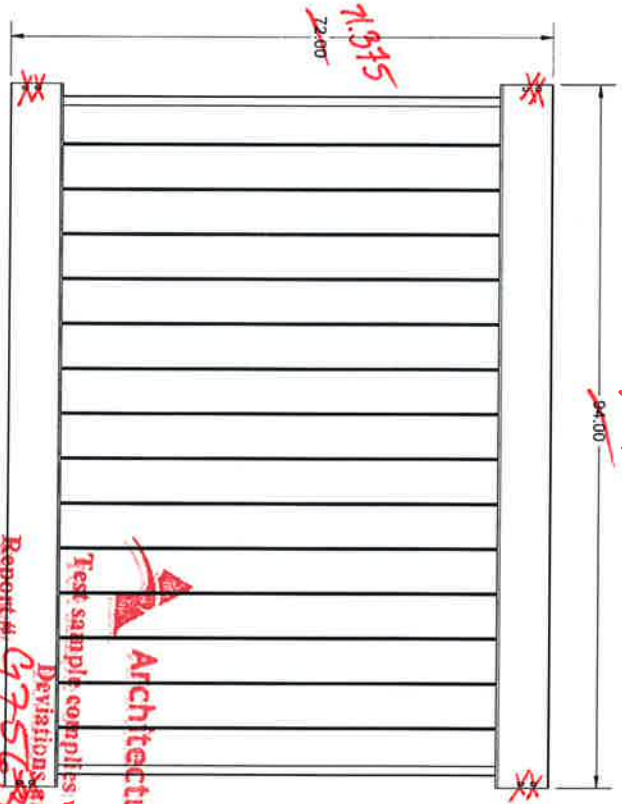
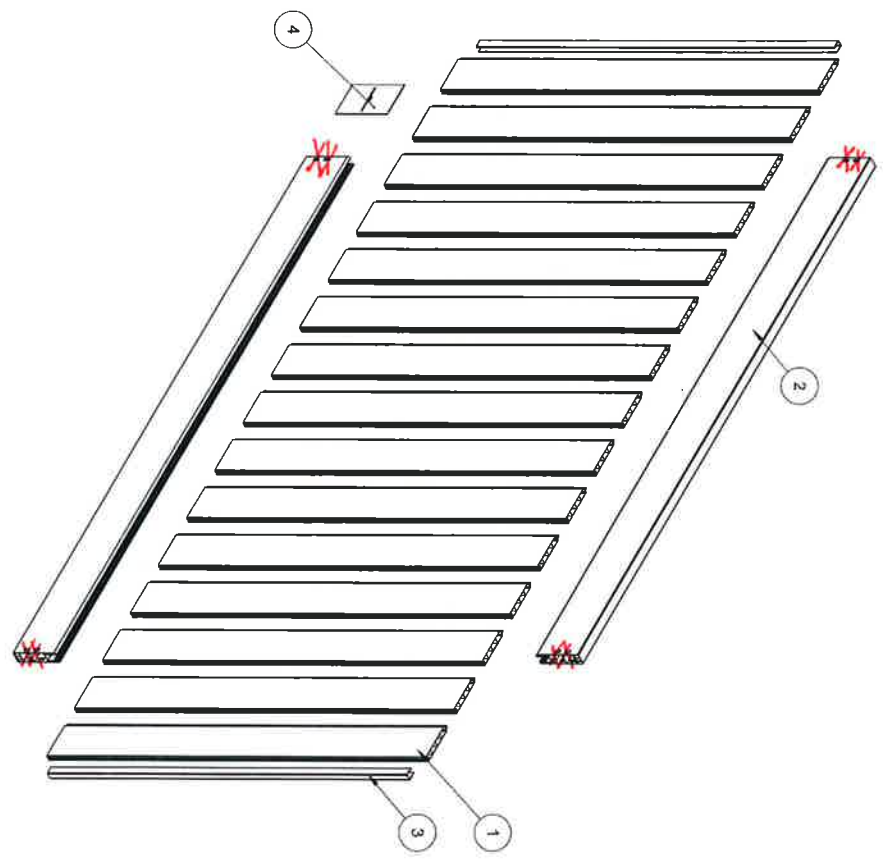

**Architectural Testing**  
 Test sample complies with these details.  
 Deviations are noted.  
 Report # 97528.01  
 Date 5/5/17 Tech RGS

ITEM NO.	73014530 WHITE	73014530 WHITE INLINE	73014533 SAND	73014533 SAND INLINE	DESCRIPTION	QTY
1	61109121	61113203	61116976	61113204	.875X6X61.5 W/.035 GLIDELOCK EXTR	15
2	61107223		61108682		1.75X7X94 DECO W/ BAR8 EXTR	2
3	61108748		61108475		1.02X1.379X58.375 EXTR U-CHANNEL	2
4			34107823		INSTRUCTIONS PRIVACY VINYL FENCE KIT	1

REV	BY	DATE	PCR	DESCRIPTION
4	CRC	7/25/2016	N/A	ADDING INSTRUCTIONS TO DRAWING; REMOVED CC GRAY
3	CRC	7/30/2015	N/A	ADDED PAGE 2; ADDED BIRCHWOOD AND BIRCHWOOD STUDS
2	CRC	3/31/2015	140929CMB-A	ADDED WHITE SAND AND RAILLINE
1	CC	6/5/2014	N/A	ADDED CC GRAY

TOLERANCES	
FRACTION	±1/16
XX	±0.01
XXX	±0.005
ANGLE	±1.0°
FINISH	125 RMS
(UNLESS OTHERWISE SPECIFIED)	

 <b>BARETTE</b> Outdoor Living 740 N. Main St., Suite 600, W. 27713	D. WRIGHT 8/29/2013 SCALE 1/16 WEIGHT 45.06 <b>CHART DRAWING</b>
--	--



# 6' High X 6' Wide / 4 Inch Post / 5.5 Inch Bracket / 5.5 Inch Bracket / Illustration

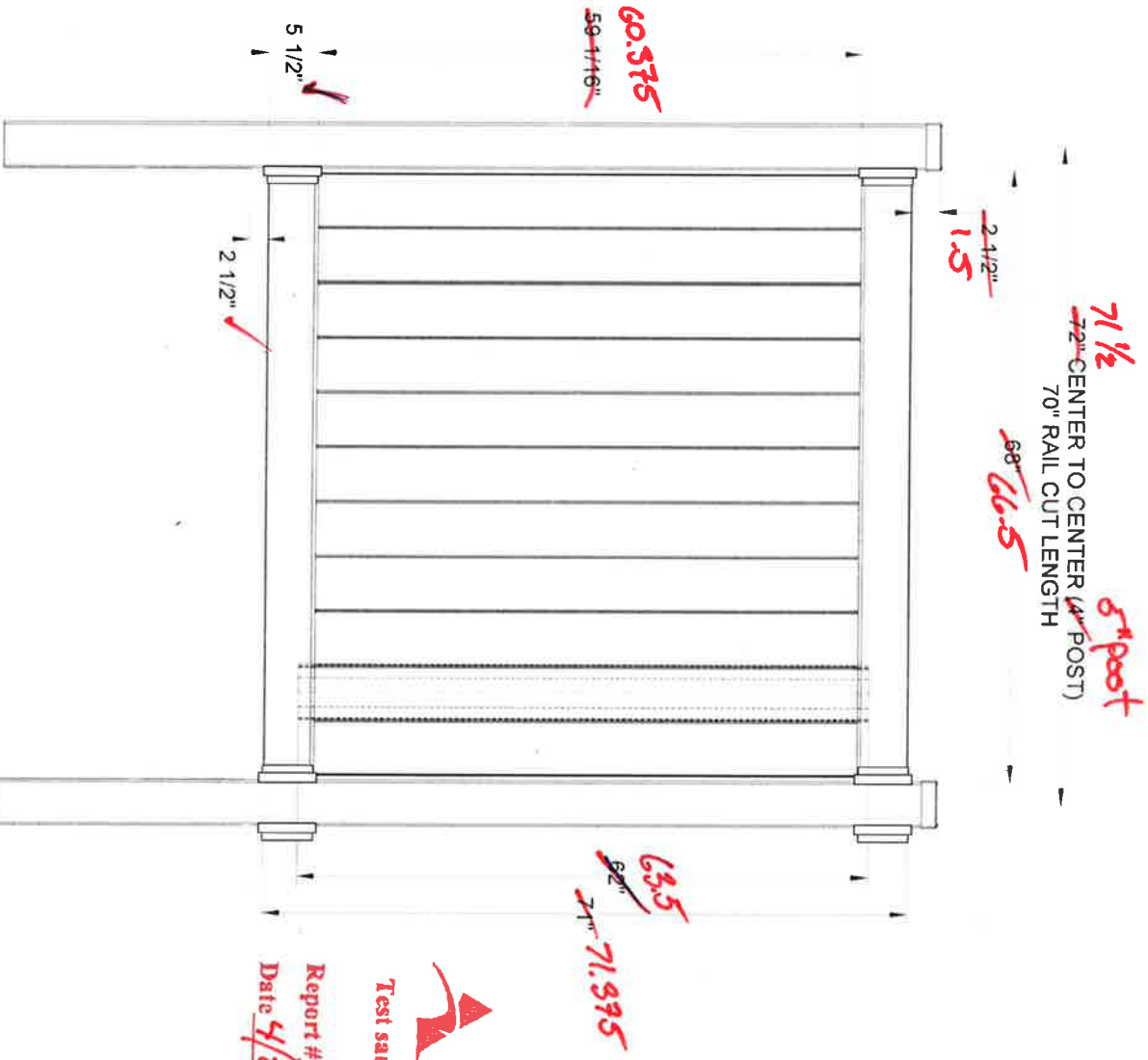

Test sample complies with these details.  
Deviations are noted.

Report # G 7663.01  
Date 4/27/17 Tech RG5



ITEM NO.	73014393 WHITE	73014393 WHITE INLINE	73014396 SAND	73014396 SAND INLINE	73014399 CYPRESS	73025616 KHAKI	DESCRIPTION	QTY
1	61108628	61113193	61108629	61113194	61108630	61117062	.875X6X62.0 W/.035W EXTR T&G	11
2	61102956		61108631		61108632	61117058	1.02X1.379X59.5 EXTR U-CHANNEL	2
3	61109144		61109145		61108610	61117070	1.75X5.47X70 DECO EXTR WHITE	2
4	34107823						INSTRUCTIONS PRIVACY VINYL FENCE KIT	1

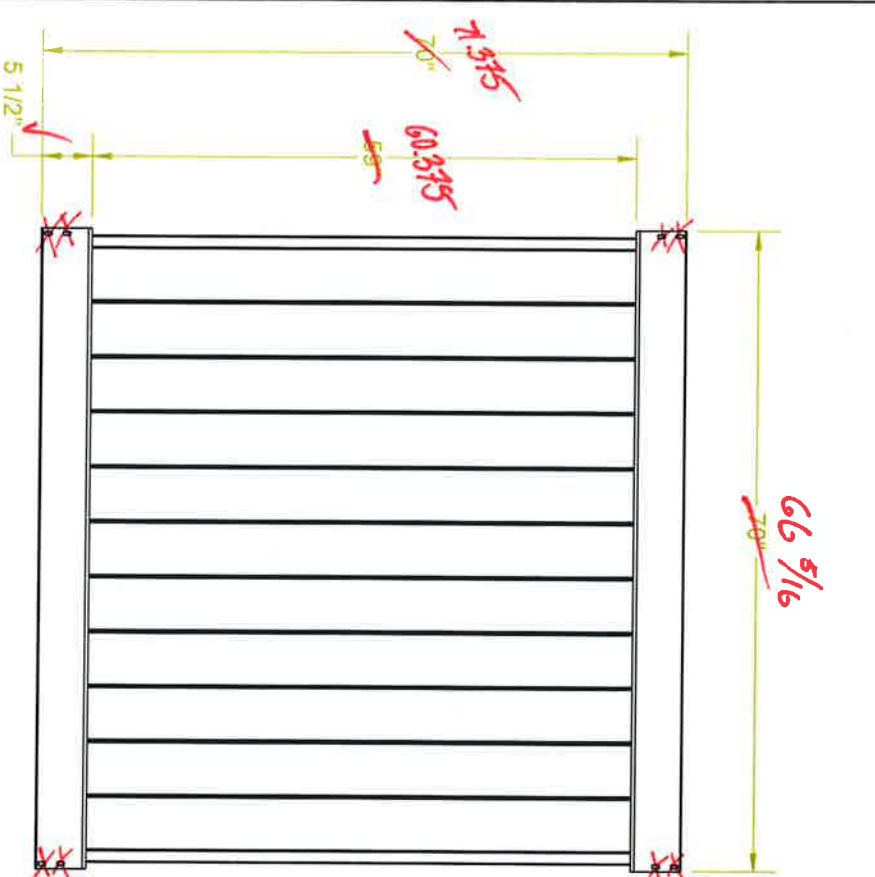

**Architectural Testing**

Test sample complies with these details.  
Deviations are noted.

Report # **G7563.01**  
Date **4/27/17** Tech **RGS**

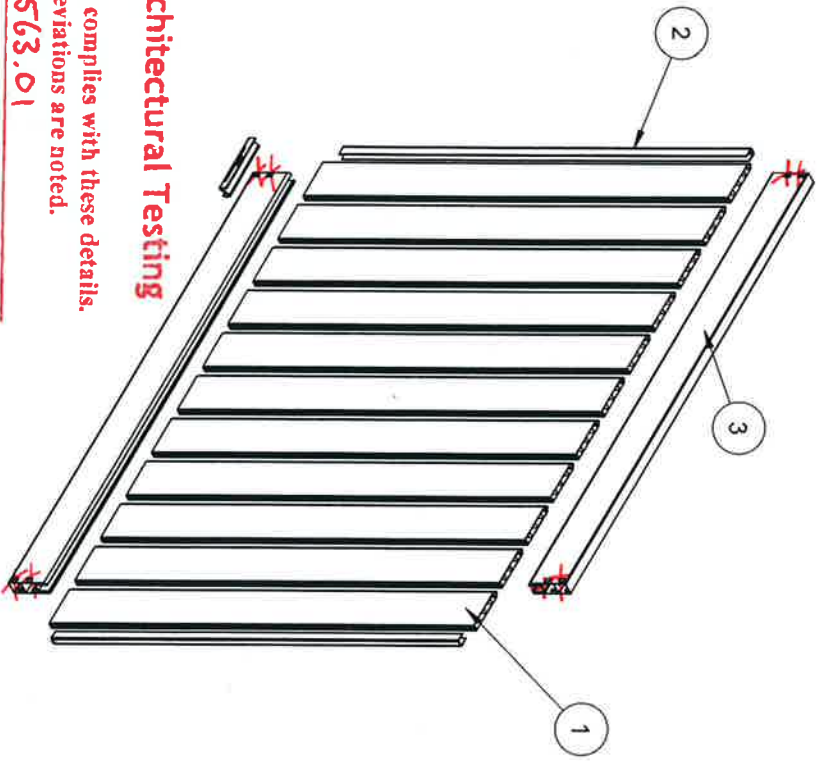

THIS DRAWING IS PROTECTED BY COPYRIGHT AND PATENT LAWS OF THE UNITED STATES AND OTHER COUNTRIES. ANY REPRODUCTION IN PART OR AS A WHOLE WITHOUT WRITTEN PERMISSION IS PROHIBITED.

REV	BY	DATE	PCR	DESCRIPTION
4	DGW	10/24/2016	161024DGW-A	ADDED KHAKI
3	CRC	7/25/2016	N/A	ADDING INSTRUCTIONS TO DRAWING
2	CRC	3/31/2015	140929CHB-A	ADDED IN LINE SKU#S
1	CRC	2/25/2015	150229DGW-A	UPDATED U-CHANNEL LENGTH

**Barrette**  
Outdoor Living

740 N. Main St., Bulls Gap, TN 37711

D. WRIGHT  
8/30/2013

6X6 5.5" PRIVACY PANEL WHITE (Z)

SHEET 1 OF 2  
SCALE 1:20  
WEIGHT: 33.72

CHART DRAWING

1-3/4" x 5-1/2" Rail Section

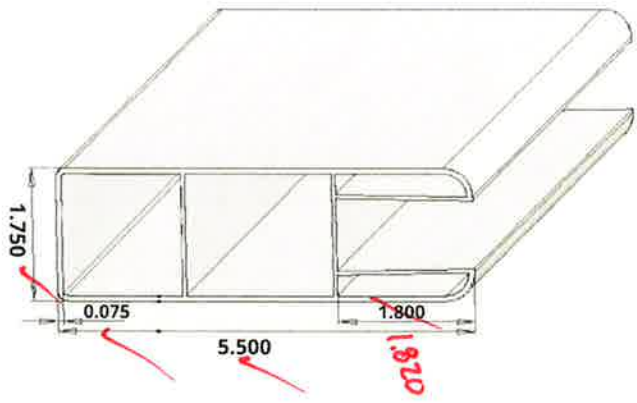

5" x 5" Post

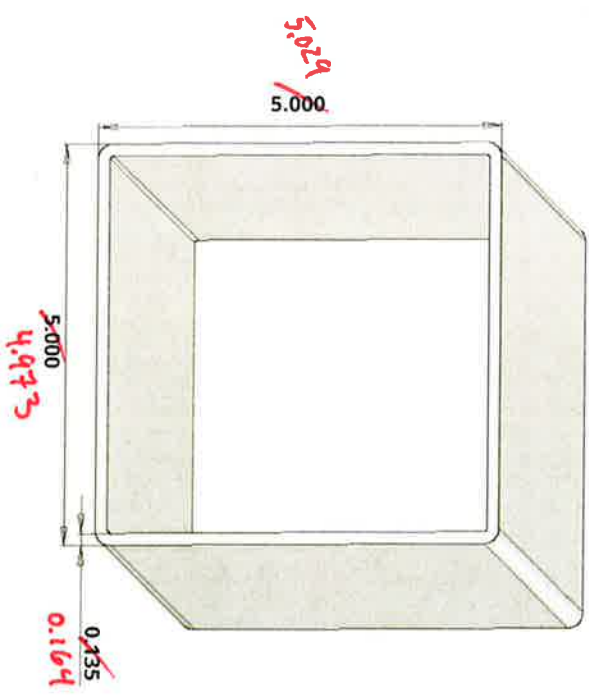

7/8" x 6" Picket

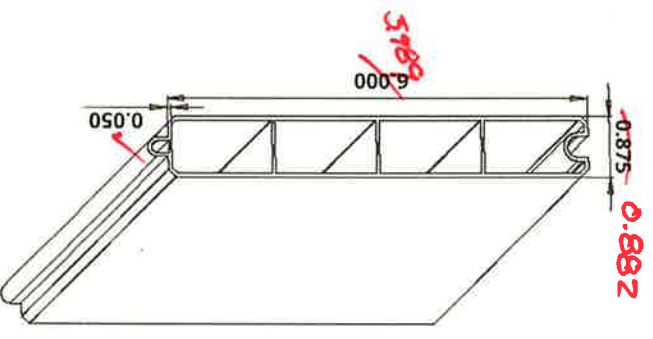

7/8" U-Channel

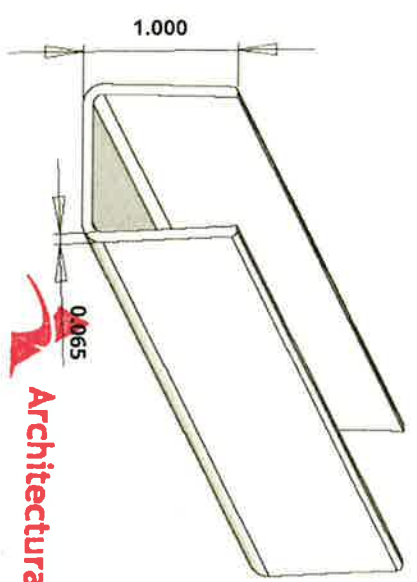

**Architectural Testing**

Test sample complies with these details.  
Deviations are noted.

Report # G7563.01

Date 5/31/17 Tech RLS







G7563.01-119-16-R2

## **APPENDIX B**

### **Photographs**



**Photo No. 1**  
**Typical Dynamic Wind Test Setup**



**Photo No. 2**  
**Transducer Locations on Backside of Fence Panels**